**Measurement of antibacterial activity on
plastics and other non-porous surfaces**

*Mesurage de l'action antibactérienne sur les surfaces en plastique et
autres surfaces non poreuses*



Reference number
ISO 22196:2011(E)

© ISO 2011



COPYRIGHT PROTECTED DOCUMENT

© ISO 2011

All rights reserved. Unless otherwise specified, no part of this publication may be reproduced or utilized in any form or by any means, electronic or mechanical, including photocopying and microfilm, without permission in writing from either ISO at the address below or ISO's member body in the country of the requester.

ISO copyright office
Case postale 56 • CH-1211 Geneva 20
Tel. + 41 22 749 01 11
Fax + 41 22 749 09 47
E-mail copyright@iso.org
Web www.iso.org

Published in Switzerland

Contents

Page

Foreword	iv
Introduction.....	v
1 Scope	1
2 Normative references	1
3 Terms and definitions	2
4 Materials	2
4.1 Bacteria to be used for the tests.....	2
4.2 Reagents, culture media and solutions	3
5 Apparatus	4
6 Sterilization of apparatus and storage of stock cultures	5
6.1 Dry-heat sterilization	5
6.2 High-pressure steam sterilization.....	5
6.3 Preparation of glassware.....	5
6.4 Maintenance of stock cultures	5
7 Procedure	6
7.1 Pre-culture of bacteria	6
7.2 Preparation of test specimens	6
7.3 Preparation of test inoculum.....	6
7.4 Inoculation of test specimens.....	6
7.5 Incubation of the inoculated test specimens	8
7.6 Recovery of bacteria from test specimens	8
7.7 Determining the viable bacteria count by the pour plate culture method.....	8
8 Expression of results	9
8.1 Determination of the number of viable bacteria.....	9
8.2 Conditions for a valid test	9
8.3 Calculation of the antibacterial activity.....	9
8.4 Effectiveness of the antibacterial agent.....	10
9 Repeatability and reproducibility.....	10
10 Test report.....	10
Annex A (normative) Quality of biological materials	11
A.1 General	11
A.2 Chemical composition of 1/500 nutrient broth (1/500 NB)	11
Annex B (informative) Repeatability and reproducibility	12
B.1 Background.....	12
B.2 Summary	12
B.3 Experiment	12
B.4 Results and discussion	13
Bibliography.....	15

Foreword

ISO (the International Organization for Standardization) is a worldwide federation of national standards bodies (ISO member bodies). The work of preparing International Standards is normally carried out through ISO technical committees. Each member body interested in a subject for which a technical committee has been established has the right to be represented on that committee. International organizations, governmental and non-governmental, in liaison with ISO, also take part in the work. ISO collaborates closely with the International Electrotechnical Commission (IEC) on all matters of electrotechnical standardization.

International Standards are drafted in accordance with the rules given in the ISO/IEC Directives, Part 2.

The main task of technical committees is to prepare International Standards. Draft International Standards adopted by the technical committees are circulated to the member bodies for voting. Publication as an International Standard requires approval by at least 75 % of the member bodies casting a vote.

Attention is drawn to the possibility that some of the elements of this document may be the subject of patent rights. ISO shall not be held responsible for identifying any or all such patent rights.

ISO 22196 was prepared by Technical Committee ISO/TC 61, *Plastics*, Subcommittee SC 6, *Ageing, chemical and environmental resistance*.

This second edition cancels and replaces the first edition (ISO 22196:2007). The main change is the extension of the scope of the standard to include non-porous surfaces other than plastics (for details, see the Introduction).

Introduction

Antibacterial materials and products have been widely and rapidly accepted by general consumers as fulfilling a relatively new function, which is distinguishable from the more traditional function of material protection.

Antibacterial products created by incorporating an antibacterial agent (biocide) can suppress the growth of bacteria on the surfaces of products when conditions exist where growth can occur. They can keep surfaces clean and sanitary and can also have an advantage in minimizing the impact on the environment by minimizing diffusion of the agent. This technology is significant for the quality of life, not only in developed countries but also in developing countries.

Antibacterial products have been widely used in plastics, coating materials, ceramics, natural and artificial leather, stainless steel, rubber, etc. The products involved cover a variety of categories, such as electrical appliances, personal items, household goods, nursing-care articles, pet accessories and aircraft-interior fittings.

The scope of the first edition of ISO 22196 was limited to plastics surfaces. In this second edition, the scope has been extended to include surfaces made of other non-porous materials, thus making the second edition applicable to products of the kinds listed above. The test method, which is based on JIS Z 2801^[1], has remained unchanged.

.....

Measurement of antibacterial activity on plastics and other non-porous surfaces

1 Scope

WARNING — Handling and manipulation of microorganisms which are potentially hazardous requires a high degree of technical competence and may be subject to current national legislation and regulations. Only personnel trained in microbiological techniques should carry out such tests. Appropriate practices for disinfection, sterilization and personal hygiene must be strictly observed.

This International Standard specifies a method of evaluating the antibacterial activity of antibacterial-treated plastics, and other non-porous, surfaces of products (including intermediate products).

It is not intended to be used to evaluate the effects and propagation of bacteria on non-porous surfaces without antibacterial treatments. ISO 846^[1] describes tests to evaluate the effects and propagation of bacteria on non-porous surfaces, which are different from those covered by this International Standard (see e.g. ISO 846:1997, method C).

Secondary effects of antibacterial treatments, such as the prevention of biodeterioration and odour, are not covered by this International Standard, which is not intended to be used or referenced as a method to document or claim biodegradability of, for instance, plastics materials. In the case of plastics, biodegradation is covered in ISO 14851^[2], ISO 14852^[3] and ISO 14855^[4] and related standards.

Building materials are excluded, except where they are used in the same manner as treated articles.

Antibacterial-treated textile products are excluded, even if the surfaces are coated or laminated (such products are covered by ISO 20743^[5]).

Photocatalytic materials and products are excluded (such materials and products are covered by ISO 27447^[6]).

The results obtained should include a reference to this International Standard and the conditions used. Results obtained with this International Standard indicate antibacterial activity under the specified experimental conditions used, and do not reflect activity under other circumstances where a variety of factors, such as temperature, humidity, different bacterial species, nutrient conditions, etc., have to be considered. A minimum diffusion of the antibacterial agents/chemicals into the test inoculum is necessary with this procedure.

It is recommended that workers consult ISO 7218.

2 Normative references

The following referenced documents are indispensable for the application of this document. For dated references, only the edition cited applies. For undated references, the latest edition of the referenced document (including any amendments) applies.

ISO 7218, *Microbiology of food and animal feeding stuffs — General requirements and guidance for microbiological examinations*

3 Terms and definitions

For the purposes of this document, the following terms and definitions apply.

3.1 antibacterial
 term describing a state where growth of bacteria on the surfaces of products is suppressed or describing the effect of an agent which suppresses the growth of bacteria on the surfaces of products

3.2 antibacterial agent
 agent that inhibits the growth of bacteria on the surfaces of products, used either as a surface treatment or as a compounded ingredient

3.3 antibacterial activity
 difference in the logarithm of the viable cell counts found on an antibacterial-treated product and an untreated product after inoculation with and incubation of bacteria

3.4 antibacterial effectiveness
 ability of an antibacterial agent to inhibit the growth of bacteria on the surface of materials treated with an antibacterial agent, as determined by the value of the antibacterial activity

4 Materials

4.1 Bacteria to be used for the tests

Both of the following species of bacteria shall be used:

- a) *Staphylococcus aureus*;
- b) *Escherichia coli*.

The bacterial strains to be used are shown in Table 1. If bacterial strains obtained from culture collections other than those shown in Table 1 are used, they shall be obtained from a member agency of the World Federation for Culture Collections (WFCC) or of the Japan Society for Culture Collections (JSCC) and shall be the same strains as those shown in Table 1. Prepare stock cultures of these species in accordance with the supplier's directions.

Table 1 — Bacterial strains to be used

Name	Strain
<i>Staphylococcus aureus</i>	ATCC 6538P CIP 53.156 DSM 346 NBRC 12732 NCIB 8625
<i>Escherichia coli</i>	ATCC 8739 CIP 53.126 DSM 1576 NBRC 3972 NCIB 8545

If required, other species can also be used, in which case the species and the reason for their use shall be included in the test report.

4.2 Reagents, culture media and solutions

Water shall be distilled or deionized and have a conductivity of $< 1 \mu\text{S}/\text{cm}$.

All reagents shall be of analytical grade and/or of a grade appropriate for microbiological purposes.

4.2.1 Nonionic surfactant

Polyoxyethylene sorbitan monooleate shall be used.

4.2.2 Biological materials

The following biological materials are required:

- lecithin;
- D-glucose;
- yeast extract;
- meat extract (see Annex A);
- peptone (see Annex A);
- casein peptone;
- soybean peptone;
- tryptone.

4.2.3 Culture medium

4.2.3.1 General

The culture medium specified below shall be used. The medium may be obtained from commercial suppliers, in which case it shall be prepared for use in accordance with the manufacturer's instructions.

The quantity of the culture medium can be changed provided the same composition is retained.

4.2.3.2 Suspension medium — 1/500 nutrient broth (1/500 NB)

Prepare nutrient broth by dissolving 3,0 g of meat extract, 10,0 g of peptone and 5,0 g of sodium chloride in 1 000 ml of distilled or deionized water. Dilute the nutrient broth with distilled or deionized water to a 500-fold volume and adjust the pH to a value between 6,8 and 7,2 with sodium hydroxide or hydrochloric acid. Sterilize by autoclaving (see 6.2). If it is not used immediately after preparation, store it at 5 °C to 10 °C. A 1/500 NB that has been kept for one week or longer after preparation shall not be used.

4.2.3.3 Nutrient agar

Prepare nutrient agar by dissolving 5,0 g of meat extract, 10,0 g of peptone, 5,0 g of sodium chloride and 15,0 g of agar powder in 1 000 ml of distilled or deionized water. Heat, with stirring, on a hotplate or in a boiling-water bath until the agar has dissolved. Adjust the pH to a value between 7,0 and 7,2 (at 25 °C) with sodium hydroxide or hydrochloric acid. Sterilize by autoclaving (see 6.2). If it is not used immediately after preparation, store it at 5 °C to 10 °C. Nutrient agar that has been kept for one month or longer after preparation shall not be used.

4.2.3.4 Plate count agar

Prepare plate count agar by dissolving 2,5 g of yeast extract, 5,0 g of tryptone, 1,0 g of glucose and 15,0 g of agar powder in 1 000 ml of distilled or deionized water. Heat, with stirring, on a hotplate or in a boiling-water bath until the agar has dissolved. Adjust the pH to a value between 7,0 and 7,2 (at 25 °C) with sodium hydroxide or hydrochloric acid. Sterilize by autoclaving (see 6.2). If it is not used immediately after preparation, store it at 5 °C to 10 °C. Plate count agar that has been kept for one month or longer after preparation shall not be used.

4.2.3.5 Slant culture medium

Warm 6 ml to 10 ml of nutrient agar and pour into a screw-capped test tube. Sterilize by autoclaving (see 6.2). After sterilization, place the test tube at an angle of about 15° to the horizontal and allow the contents to solidify. If it is not used immediately after preparation, store it at 5 °C to 10 °C. Slant culture medium kept for one month or longer after preparation shall not be used.

4.2.3.6 Soybean casein digest broth with lecithin and polyoxyethylene sorbitan monooleate (SCDLP broth)

Prepare SCDLP broth by dissolving 17,0 g of casein peptone, 3,0 g of soybean peptone, 5,0 g of sodium chloride, 2,5 g of disodium hydrogen phosphate, 2,5 g of glucose and 1,0 g of lecithin in 1 000 ml of distilled or deionized water. Mix thoroughly and add 7,0 g of nonionic surfactant. Adjust the pH to a value between 6,8 and 7,2 (at 25 °C) with sodium hydroxide or hydrochloric acid. Sterilize by autoclaving (see 6.2). If it is not used immediately after preparation, store it at 5 °C to 10 °C. SCDLP broth kept for one month or longer after preparation shall not be used.

NOTE SCDLP is the default neutralizer in the majority of circumstances. Information about selection and evaluation of alternative antibacterial neutralizing agents can be found in ASTM E1054^[7] and EN 1040^[8].

4.2.3.7 Phosphate buffer solution

Prepare phosphate buffer solution by placing 34,0 g of potassium dihydrogen phosphate in a 1 000 ml volumetric flask. Add 500 ml of distilled or deionized water and mix to dissolve. Adjust the pH to a value between 6,8 and 7,2 (at 25 °C) with sodium hydroxide. Add distilled or deionized water to make up to 1 000 ml. Sterilize by autoclaving (see 6.2). Phosphate buffer solution kept for one month or longer after preparation shall not be used.

4.2.3.8 Phosphate-buffered physiological saline

Prepare physiological saline by placing 8,5 g of sodium chloride in 1 000 ml of distilled or deionized water and mixing to dissolve. Dilute the phosphate buffer solution prepared in 4.2.3.7 with the physiological saline to an 800-fold volume. Sterilize the phosphate-buffered physiological saline solution by autoclaving (see 6.2). If this solution is not used immediately after preparation, store it at 5 °C to 10 °C. Phosphate-buffered physiological saline kept for one month or longer after preparation shall not be used.

5 Apparatus

Unless otherwise specified, use the following apparatus and materials:

- 5.1 **Dry-heat sterilizer**, capable of maintaining the temperature at a value between 160 °C and 180 °C within ± 2 °C of the set point at equilibrium conditions.
- 5.2 **Autoclave**, capable of maintaining a temperature of (121 ± 2) °C and a pressure of (103 ± 5) kPa.
- 5.3 **Hotplate with stirrer**, or **hot-water bath**.
- 5.4 **pH-meter**, capable of measuring to $\pm 0,2$ units.

- 5.5 Balance**, capable of weighing to $\pm 0,01$ g.
- 5.6 Pipettors**, sterile, with 1 000 μl tips.
- 5.7 Incubator**, capable of maintaining the temperature within ± 1 °C of the set point at equilibrium conditions.
- 5.8 Vortex mixer**, if required (see 7.6.1).
- 5.9 Sonicator**, if required (see 7.6.1).
- 5.10 Inoculating loops**, 4 mm in ring diameter, sterile.
- 5.11 Cover film**, that does not affect bacterial growth or absorb water, made of polyethylene, polypropylene or polyester [poly(ethylene terephthalate)]. Film that is 0,05 mm to 0,10 mm thick is recommended.
- NOTE Films cut from Stomacher bags are also suitable.
- 5.12 Screw-capped test tubes**.
- 5.13 Petri dishes**, sterile, 90 mm to 100 mm in diameter.
- 5.14 Gauze or absorbent cotton**.
- 5.15 1 000 ml volumetric flask**.
- 5.16 Stoppered Erlenmeyer flasks or media bottles**, as required for preparation of media.

6 Sterilization of apparatus and storage of stock cultures

6.1 Dry-heat sterilization

Place objects to be sterilized in a dry-heat sterilizer, using the following minimum times for the given temperature:

Temperature	Minimum sterilization time
180 °C	30 minutes
170 °C	60 minutes
160 °C	120 minutes

6.2 High-pressure steam sterilization

Put the objects to be sterilized in an autoclave and maintain at (121 ± 2) °C for at least 15 min.

6.3 Preparation of glassware

Wash well with alkali or neutral detergent, then rinse well with distilled or deionized water. Sterilize using dry heat or an autoclave prior to use.

6.4 Maintenance of stock cultures

Stock cultures shall be stored at 5 °C to 10 °C on an appropriate medium and transferred monthly. After five transfers or if more than one month has passed between transfers, the stock culture shall be discarded and replaced with a fresh culture obtained from the institute or culture collection concerned.

7 Procedure

7.1 Pre-culture of bacteria

Using a sterile inoculating loop, transfer bacteria from the stock culture to the slant culture medium (4.2.3.5) and incubate at $(35 \pm 1)^\circ\text{C}$ for 16 h to 24 h. From this culture, use a sterile inoculating loop to transfer bacteria onto fresh slant culture medium and incubate at $(35 \pm 1)^\circ\text{C}$ for 16 h to 20 h.

7.2 Preparation of test specimens

Testing shall be performed on at least three specimens from each treated test material. At least six specimens of the untreated material are required. Half of the untreated test specimens are used to measure viable cells immediately after inoculation and half are used to measure viable cells after incubation for 24 h.

NOTE Use of more than three replicate specimens of the treated test material can help reduce variability, especially for materials that show smaller antimicrobial effects.

When testing a series of antibacterial treatments for a single polymer, each antibacterial treatment may be compared to the same single set of untreated specimens if all tests are conducted at the same time using the same test inoculum.

Prepare flat $(50 \pm 2) \text{ mm} \times (50 \pm 2) \text{ mm}$ specimens of the treated and untreated test materials. Specimens should be no more than 10 mm in thickness. If it is difficult or impossible to cut the product into a square of this size, then test specimens of other sizes and shapes may be used, as long as they can be covered with a film of surface area between 400 mm^2 and $1\,600 \text{ mm}^2$. It is preferable to prepare test specimens from the final product itself. However, if the shape of the product prevents this, then the test specimens may be prepared in a format suitable for testing using the same raw materials and processing methods as are normally used for the product. If the test specimen differs from the $50 \text{ mm} \times 50 \text{ mm}$ square dimensions, the actual dimensions used shall be stated in the test report.

When preparing specimens, take care to avoid contamination with microorganisms or extraneous organic debris. Similarly, do not allow specimens to come into contact with each other. If metal apparatus is used to avoid cross-contamination, it is necessary to ensure that the metal does not have any antibacterial effect. If necessary, test specimens can be cleaned/disinfected/sterilized prior to testing (e.g. by wiping with 70 % ethanol in water).

Cleaning of the test specimen can cause softening, dissolution of the surface coating or elution of components, so should be avoided. If cleaning is required due to gross contamination, the cleaning method shall be stated in the test report.

7.3 Preparation of test inoculum

Using a sterile inoculating loop, transfer one loop of the test bacteria, pre-incubated as specified in 7.1, into a small amount of 1/500 NB prepared in accordance with 4.2.3.2. Ensure that the test bacteria are evenly dispersed, and estimate the number of bacteria using direct microscopic observation and a counting chamber or another appropriate method (e.g. spectrophotometrically). Dilute this suspension with 1/500 NB, as appropriate for the estimated bacterial concentration, to obtain a bacterial concentration that is between $2,5 \times 10^5$ cells/ml and 10×10^5 cells/ml, with a target concentration of 6×10^5 cells/ml. Use this solution as the test inoculum. If the test inoculum is not used immediately, then chill it on ice (0°C) and use it within 2 h of preparation.

7.4 Inoculation of test specimens

The surface to be tested is the exposed outer surface of the product. Cross-sections of the product shall not be used. Place each test specimen prepared in accordance with 7.2 into a separate sterile Petri dish with the test surface uppermost. Pipette 0,4 ml of the test inoculum prepared in accordance with 7.3 onto the test surface. Cover the test inoculum with a piece of film (5.11) that measures $40 \text{ mm} \times 40 \text{ mm}$ and gently press

down on the film so that the test inoculum spreads to, but does not leak beyond, the edges of the film. After the specimen has been inoculated and the cover film applied, replace the lid of the Petri dish (see Figure 1).

Dimensions in millimetres

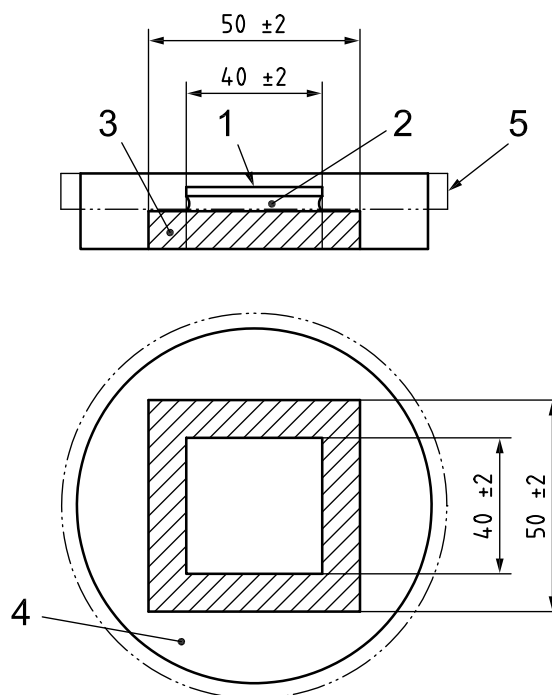

Key

- 1 cover film
- 2 test inoculum (0,4 ml)
- 3 test specimen
- 4 Petri dish
- 5 lid of Petri dish

Figure 1 — Inoculation of test specimen and placement of cover film

Unless otherwise specified, the standard size of the cover film shall be a square of (40 ± 2) mm \times (40 ± 2) mm for the 50 mm \times 50 mm test specimen. If the test specimen is not of a standard size, then the size of the film shall be reduced in direct proportion. Do not, however, reduce the size of the film to less than 400 mm² and the edges of the cover film shall always be 2,5 mm to 5,0 mm inside the edge of the test specimen on all sides. If the size of the cover film differs from 40 mm \times 40 mm, the actual size used shall be stated in the test report. The volume of inoculum used shall also be adjusted to be in proportion to the area of the cover film used, and the volume shall be recorded in the test report.

It is essential that the test inoculum does not leak beyond the edges of the cover film. However, for some surfaces (e.g. those that are very hydrophilic), this might be difficult to achieve. When leakage occurs, use option 1 below. If leakage still occurs with option 1, use option 2. If one of these options is used to ensure that leaking does not occur, it shall be described in the test report.

- Option 1: Reduce the volume of test inoculum applied to the test surface, but do not use less than 0,1 ml. When the volume of test inoculum is decreased, the concentration of the bacterial cells in the inoculum shall be increased to provide the same number of bacterial cells as when the normal volume of test inoculum is applied.
- Option 2: Increase the viscosity of the test inoculum by adding an inert thickener such as agar.

7.5 Incubation of the inoculated test specimens

Unless otherwise specified, incubate the Petri dishes containing the inoculated test specimens (including half of the untreated test specimens) at a temperature of (35 ± 1) °C and a relative humidity of not less than 90 % for (24 ± 1) h. The antibacterial effectiveness of a product is evaluated based on the value of the antibacterial activity obtained from the test at the incubation temperature specified. Other temperatures may be used if agreed by the interested parties. If a temperature other than (35 ± 1) °C is used, it shall be included in the test report.

NOTE If incubation temperatures of less than 35 °C are used, the total count of the viable bacteria might be reduced. This might affect the antibacterial activity compared to measurements conducted using a 35 °C incubation temperature.

7.6 Recovery of bacteria from test specimens

7.6.1 Test specimens immediately after inoculation

Immediately after inoculation, process half of the untreated test specimens by adding 10 ml of either SCDLP broth (4.2.3.6) or a suitable, validated neutralizer to the Petri dish containing the test specimen. The value obtained from these test specimens will be used to determine the recovery rate of the bacteria from the test specimens under investigation. It is important to ensure that the neutralizer completely washes the specimens by using a pipette to collect and release the SCDLP broth at least four times.

Special consideration might be required to achieve sufficient recovery, especially if option 2 in 7.4 has been taken and the viscosity of the inoculum has been increased. In this case, mechanical agitation may be required, such as stomaching, vortexing or sonicating. If these show a recovery rate equivalent to or superior to that obtained using the method above, such methods may be used. If an alternative recovery method is used, it shall be described in the test report. If it is difficult to recover the test bacteria with 10 ml of the neutralizer due to the size and characteristics of the test specimen, then the volume of solution may be increased. If the volume of the neutralizer used is different from 10 ml, the actual volume used shall be included in the test report and taken account of in the calculation of the antibacterial effect.

Use of alternative washing procedures might affect the measured antibacterial activity and shall therefore be fully validated.

7.6.2 Test specimens after incubation

After the incubation in accordance with 7.5, process the remaining test specimens in accordance with 7.6.1. Proceed immediately to count the viable bacteria recovered from the test specimen (see 7.7).

7.7 Determining the viable bacteria count by the pour plate culture method

Enumerate viable bacteria by performing 10-fold serial dilutions of the SCDLP in phosphate-buffered physiological saline (4.2.3.8). Place 1 ml of each dilution, as well as 1 ml of the SCDLP recovered from the test specimen, into separate sterile Petri dishes. Pour 15 ml of plate count agar (4.2.3.4) into each Petri dish and swirl gently to disperse the bacteria. All plating shall be performed in duplicate. Replace the lids, invert the Petri dishes and incubate them at (35 ± 1) °C for 40 h to 48 h.

After incubation, count the number of colonies in the Petri dishes containing 30 to 300 colonies. For each dilution series, record the number of colonies recovered to two significant figures, as well as the dilution factor for the plates used for counting. If the number of colonies in the plates containing the 1 ml aliquots of SCDLP is less than 30, then count and record the number of colonies in these plates. If there are no colonies recovered in any of the agar plates in the dilution series, record the number of colonies as "< 1".

8 Expression of results

8.1 Determination of the number of viable bacteria

For each test specimen, determine the number of viable bacteria recovered in accordance with Equation (1):

$$N = (100 \times C \times D \times V) / A \quad (1)$$

where

N is the number of viable bacteria recovered per cm^2 per test specimen;

C is the average plate count for the duplicate plates;

D is the dilution factor for the plates counted;

V is the volume, in ml, of SCDLP added to the specimen;

A is the surface area, in mm^2 , of the cover film.

Calculate the geometric mean of the number of viable bacteria recovered for each set of test specimens and express this value to two significant figures. If no colonies were recovered in any of the agar plates for a dilution series, then record the number of colonies counted as “< V ” (where V is the volume, in ml, of SCDLP added to the specimen). For calculating the average when there are no viable bacteria recovered in a dilution series, consider the number of viable bacteria to be “ V ”.

EXAMPLE In the case of $V = 10$ ml, the number used for calculating the average will be 10.

8.2 Conditions for a valid test

8.2.1 When the three conditions given in 8.2.2, 8.2.3 and 8.2.4, respectively, are satisfied, the test is deemed valid. If any of these conditions are not met, the test is not considered valid and the specimens shall be retested.

8.2.2 The logarithmic value of the number of viable bacteria recovered immediately after inoculation from the untreated test specimens shall satisfy the following requirement:

$$(L_{\max} - L_{\min}) / (L_{\text{mean}}) \leq 0,2 \quad (2)$$

where

L_{\max} is the common logarithm (i.e. base 10 logarithm) of the maximum number of viable bacteria found on a specimen;

L_{\min} is the common logarithm of the minimum number of viable bacteria found on a specimen;

L_{mean} is the common logarithm of the mean number of viable bacteria found on the specimens.

8.2.3 The average number of viable bacteria recovered immediately after inoculation from the untreated test specimens shall be within the range $6,2 \times 10^3$ cells/ cm^2 to $2,5 \times 10^4$ cells/ cm^2 .

8.2.4 The number of viable bacteria recovered from each untreated test specimen after incubation for 24 h shall not be less than $6,2 \times 10^1$ cells/ cm^2 .

8.3 Calculation of the antibacterial activity

When the test is deemed valid, calculate the antibacterial activity using Equation (3), recording the result to one decimal place.

$$R = (U_t - U_0) - (A_t - U_0) = U_t - A_t \quad (3)$$

where

- R is the antibacterial activity;
- U_0 is the average of the common logarithm of the number of viable bacteria, in cells/cm², recovered from the untreated test specimens immediately after inoculation;
- U_t is the average of the common logarithm of the number of viable bacteria, in cells/cm², recovered from the untreated test specimens after 24 h;
- A_t is the average of the common logarithm of the number of viable bacteria, in cells/cm², recovered from the treated test specimens after 24 h.

8.4 Effectiveness of the antibacterial agent

The value of the antibacterial activity can be used to characterize the effectiveness of an antibacterial agent. The antibacterial-activity values used to define the effectiveness shall be agreed upon by all interested parties.

9 Repeatability and reproducibility

Repeatability and reproducibility are discussed quantitatively in Annex B.

10 Test report

The test report shall include the following information:

- a) a reference to this International Standard;
- b) the type of material used for the treated and untreated test specimens, and the size, shape and thickness of the specimens;
- c) the type of polymer used for the cover film and the size, shape and thickness of the film;
- d) the species of test bacteria used and their strain numbers, indicating the reason if other species of bacteria were used;
- e) the volume of test inoculum used;
- f) the number of viable bacteria in the test inoculum;
- g) the values of U_0 , U_t and A_t used in 8.3;
- h) the antibacterial activity calculated;
- i) details of any deviation from this International Standard as well as details of any alternative procedures, if used, including cleaning of the test specimens, the use of inert thickeners, the type and volume of neutralizer used, the use of an alternative recovery method and the use of an alternative incubation temperature;
- j) identification of the test laboratory, and the name and signature of the head of the laboratory;
- k) the date of commencement of the experiments;
- l) the date of the test report.

Annex A (normative)

Quality of biological materials

A.1 General

The quality of the components used in the inoculum preparations might differ depending on the source, and this might cause significant variability in results. Therefore, the composition of the components used needs to be specified.

A.2 Chemical composition of 1/500 nutrient broth (1/500 NB)

The meat extract and peptone used for the 1/500 NB test inoculum are the key components in minimizing variability. The following are the total nitrogen and α -amino nitrogen composition requirements for any commercially available material used for this International Standard. The peptone shall be an enzymatic digest of casein.

Meat extract

total nitrogen 6,0 % to 15,0 %;

α -amino nitrogen 2,0 % to 5,0 %.

Peptone (enzymatic digest of casein)

total nitrogen 12,0 % to 16,0 %;

α -amino nitrogen 3,0 % to 6,0 %.

Annex B (informative)

Repeatability and reproducibility

B.1 Background

The content of this annex is based on the results of extensive research conducted to investigate the repeatability and reproducibility of the results from this method. This research was conducted from 2000 to early 2004 by the National Institute of Technology and Evaluation in Japan, partly to adopt ISO/IEC 17025^[10] as part of the Japan National Laboratory Accreditation System (see Reference [9]) and partly to determine the uncertainties for JIS Z 2801^[11], the method on which this International Standard is based.

B.2 Summary

The repeatability and reproducibility of this method were determined by means of statistical analysis in accordance with ISO 5725-2^[12]. Antibacterial activity test results obtained in interlaboratory testing at five Japanese laboratories with two types of treated test specimen by replicate tests were examined. Following rejection of the data from one laboratory, analysis of the remaining data gave the following results:

repeatability of identical test items in the same laboratory = 0,087;

reproducibility of identical test items in different laboratories = 0,304.

These figures are examples of the repeatability and reproducibility which can be obtained with this method, and should not be rigorously applied to acceptance or rejection of laboratory test results obtained with different test items.

B.3 Experiment

The materials included in the interlaboratory testing and the test conditions used are summarized in Table B.1.

Table B.1 — Materials and test conditions

Antibacterial-treated specimens	PET film, 40 mm square, 0,055 mm thick Type I specimen: acrylic coating with 350 µg/g of Ag compound Type II specimen: acrylic coating with 450 µg/g of Ag compound
Untreated control specimens	PET film, as above, but without the Ag compound in the acrylic coating
Cover film	PE film, 50 mm square, 0,09 mm thick
Bacterial strain	<i>Staphylococcus aureus</i> NBRC 12732 (see the Note)
Volume of inoculum	0,4 ml
NOTE	Only <i>Staphylococcus aureus</i> was used because it was known to show higher variability than <i>Escherichia coli</i> .

Each of the five laboratories that participated in the interlaboratory testing carried out replicate tests with the two types of treated specimen. The number of specimens used at each stage was as specified in this International Standard. The specimens, as well as the bacteria, culture media, etc., were supplied to the laboratories prior to testing.

The specimens consisted of PET films with water-soluble acrylic coatings. A specific amount of antibacterial agent, a silver compound, was dispersed in the acrylic polymer solution before it was coated on the PET. This ensured uniform amounts of antibacterial agent on the test specimens. Because the acrylic coating was water-soluble, the inoculum tended to spread over an area which was wider than the cover film. A specimen/film configuration different from that described in this International Standard was therefore used, viz the cover film was put in place first, it was inoculated and then a specimen was placed on it.

Sometimes, there is a big difference in survival of the bacteria on a blank control film and the untreated material (0 ppm). It might not be possible to create a truly blank material, as the additive either forms an integral part of the material or is only the carrier for the material, and the relevant untreated system would be an uncoated substrate rather than a substrate without the additive. Therefore, in some cases, a comparison with a reference material should be made to understand this effect.

B.4 Results and discussion

In the primary analysis, the Z -score calculated by split-plot analysis for one laboratory exceeded 2,0. Thus the results from that laboratory were rejected and data analysis was conducted only on the test results reported by the remaining four laboratories. Table B.2 shows the mean antibacterial activity and standard deviation for each type of antibacterial-treated specimen. The replicate tests are indicated in the table as "1st block" and "2nd block".

Table B.2 — Mean antibacterial activity and standard deviation

Specimen type (see Table B.1)	Mean antibacterial activity (with standard deviation in brackets)	
	1st block	2nd block
Type I specimen	1,72 (0,42)	1,78 (0,26)
Type II specimen	2,29 (0,45)	2,42 (0,41)

Two replicate tests were performed by each laboratory on each of the two types of specimen. For each type of test specimen, three specimens were used. Sources of variability considered in the analysis of the results included the variability between the replicate tests V_R (i.e. whether the results came from the 1st block or the 2nd block), the laboratory that performed the test V_L and variability between the three specimens tested V_S . However, factors V_R and V_L cannot be randomized, so a separate analysis was performed on each block. Table B.3 shows the results from the analysis of variance (ANOVA) and the calculated uncertainty.

Table B.3 — ANOVA table and uncertainty

Source of variability	Sum of squares	Degrees of freedom	Mean square	F -ratio	F ($p = 0,05$)	F ($p = 0,01$)	F (test)
Replication, V_R	0,120 0	1	0,120 0	0,40	10,13	34,12	
Laboratory, V_L	4,656 9	3	1,552 3	5,18	9,28	29,46	
$V_R \times V_L$ (1st-order error, e_1)	0,899 1	3	0,229 7	13,84	2,90	4,46	a
Test specimens, V_S	4,440 8	1	4,440 8	205,12	4,15	7,50	a
$V_L \times V_S$	0,388 7	3	0,129 6	5,98	2,90	4,46	a
$V_R \times V_S$	0,013 3	1	0,013 3	0,62	4,15	7,50	
$V_R \times V_L \times V_S$	0,116 0	3	0,038 7	1,79	2,90	4,46	
2nd-order error, e_2	0,692 8	32	0,021 7				
Total	11,327 7	47					

a Significant at 1 % level.

As indicated in Table B.3, the main-plot error $V_R \times V_L$ (the first-order error e_1) is highly significant at the 1 % level compared with the second-order error e_2 . On the other hand, no statistical significance is indicated for $V_R \times V_S$ and $V_R \times V_L \times V_S$ compared with e_2 , so the effects of these two were pooled into a sub-plot error e_2' . Table B.4 shows the result of the analysis of variance after pooling the non-significant variations.

Table B.4 — ANOVA table and uncertainty (non-significant variations pooled)

Source of variability	Sum of squares	Degrees of freedom	Mean square	F-ratio	F (p = 0,05)	F (p = 0,01)	F (test)
Replication, V_R	0,120 0	1	0,120 0	0,40	10,13	34,12	
Laboratory, V_L	4,656 9	3	1,552 3	5,18	9,28	29,46	
$V_R \times V_L$ (1st-order error, e_1)	0,899 1	3	0,229 7	13,84	2,90	4,46	a
Test specimens, V_S	4,440 8	1	4,440 8	194,46	4,11	7,50	a
$V_L \times V_S$	0,388 7	3	0,129 6	5,67	2,87	4,46	a
2nd-order error, e_2'	0,822 1	36	0,022 8				
Total	11,327 7	47					

^a Significant at 1 % level.

These results confirm that V_R , i.e. the variability due to test replication, and V_L , i.e. the variability due to the laboratory, are individually not statistically significant.

The following conclusions can be drawn from the results of this research:

- Repeatability: the standard uncertainty under repeatability conditions of three repeated measurements can be calculated from the above figures as follows:

$$\sigma(e_2) = [V(e'_2)/3]^{1/2} = (0,022\ 8/3)^{1/2} = 0,087$$

- Reproducibility: the standard uncertainty under reproducibility conditions can be calculated from the above figures as follows:

$$\sigma(e_1) = \{[V(e_1) - V(e'_2)]/3\}^{1/2} = [(0,299\ 7 - 0,022\ 8)/3]^{1/2} = 0,304$$

Bibliography

- [1] ISO 846:1997, *Plastics — Evaluation of the action of microorganisms*
- [2] ISO 14851, *Determination of the ultimate aerobic biodegradability of plastic materials in an aqueous medium — Method by measuring the oxygen demand in a closed respirometer*
- [3] ISO 14852, *Determination of the ultimate aerobic biodegradability of plastic materials in an aqueous medium — Method by analysis of evolved carbon dioxide*
- [4] ISO 14855 (both parts), *Determination of the ultimate aerobic biodegradability of plastic materials under controlled composting conditions — Method by analysis of evolved carbon dioxide*
- [5] ISO 20743, *Textiles — Determination of antibacterial activity of antibacterial finished products*
- [6] ISO 27447, *Fine ceramics (advanced ceramics, advanced technical ceramics) — Test method for antibacterial activity of semiconducting photocatalytic materials*
- [7] ASTM E1054, *Standard Test Methods for Evaluation of Inactivators of Antimicrobial Agents*
- [8] EN 1040, *Chemical disinfectants and antiseptics — Quantitative suspension test for the evaluation of basic bactericidal activity of chemical disinfectants and antiseptics — Test method and requirements (phase 1)*
- [9] *Establishment of Traceability and Estimation of Uncertainty in Evaluation Methods using Bacteria*, International Accreditation Japan/National Institute of Technology and Evaluation (IA Japan/NITE) report, March 2004
- [10] ISO/IEC 17025, *General requirements for the competence of testing and calibration laboratories*
- [11] JIS Z 2801, *Antimicrobial products — Test for antimicrobial activity and efficacy*
- [12] ISO 5725-2, *Accuracy (trueness and precision) of measurement methods and results — Part 2: Basic method for the determination of repeatability and reproducibility of a standard measurement method*

ICS 83.080.01

Price based on 15 pages